



anti-Annexin V (human) ELISA Kit

Manufactured by Bender MedSystems.

ALX-850-040-KI01

96 wells (~80 tests)

(Version 20: July 18, 2008)

NORTH/SOUTH AMERICA

ENZO LIFE SCIENCES
INTERNATIONAL, INC.
5120 Butler Pike
Plymouth Meeting, PA 19462-1202
USA
Phone: 1-800-942-0430/(610) 941-0430
Fax: (610) 941-9252
E-mail: info-usa@enzolifesciences.com

GERMANY

ENZO LIFE SCIENCES GMBH
Marie-Curie-Strasse 8
DE-79539 Lörrach
Germany
Phone: +49/0 7621 5500 526
Fax: +49/0 7621 5500 527
E-mail: info-de@enzolifesciences.com

SWITZERLAND & REST OF EUROPE

ENZO LIFE SCIENCES AG
Industriestrasse 17, Postfach
CH-4415 Lausen
Switzerland
Phone: +41/0 61 926 89 89
Fax: +41/0 61 926 89 79
E-mail: info-ch@enzolifesciences.com

BENELUX

ENZO LIFE SCIENCES BVBA
Melkerijweg 3
BE-2240 Zandhoven
Belgium
Phone: +32/0 3 466 04 20
Fax: +32/0 3 466 04 29
E-mail: info-be@enzolifesciences.com

UK & IRELAND

ENZO LIFE SCIENCES (UK) LTD.
Palatine House
Matford Court
Exeter EX2 8NL
UK
Phone: 0845 601 1488 (UK customers)
+44/0 1392 825900 (from overseas)
Fax: +44/0 1392 825910
E-mail: info-uk@enzolifesciences.com

www.enzolifesciences.com

For laboratory use only. Not for human or diagnostic use.



TABLE OF CONTENTS

1	Intended Use	3
2	Summary	3
3	Principles of the Test	5
4	Reagents Provided	6
5	Storage Instructions – ELISA Kit	8
6	Specimen Collection and Storage Instructions	8
7	Materials Required But Not Provided	9
8	Precautions for Use	10
9	Preparation of Reagents	12
10	Test Protocol	16
11	Calculation of Results	21
12	Limitations	24
13	Performance Characteristics	25
14	Bibliography	30
15	Ordering Information	32
16	Reagent Preparation Summary	33
17	Test Protocol Summary	34

1 Intended Use

The human anti-Annexin V ELISA is an enzyme-linked immunosorbent assay for the quantitative detection of antibodies to human Annexin V (Vac- α). **The human anti-Annexin V ELISA is for research use only. Not for diagnostic or therapeutic procedures.**

2 Summary

Annexins are a family of calcium-dependent phospholipid-binding proteins. They are abundant in the eukaryotic kingdom. Though structurally well investigated (4) the *in vivo* function of the annexins is still unclear (1). They definitively belong to a family of ubiquitous cytoplasmic proteins involved in signal transduction. All annexins have been shown to have putative binding site for protein kinases C but only annexin V would possess a potential pseudo-substrate site. Thus annexin V seems to modulate the activity of some PKCs on their substrates (2).

Annexin V was found to play a major role in matrix vesicle-initiated cartilage calcification as a collagen-regulated calcium channel (14). Annexin V's preferential binding partner is phosphatidylserine (PS). PS is predominantly located in membrane leaflets, which face the cytosol. However, recent findings show that each cell type has the molecular machinery to expose PS at its cell surface. This machinery is activated during the execution of apoptosis. Once PS is exposed at the cell surface it exhibits procoagulant and proinflammatory activities. Annexin V will bind to the PS-exposing apoptotic cell and can inhibit the procoagulant and proinflammatory activities of the dying cell. These findings together with the presence of Annexin V in the extracellular space depict a novel pathophysiological significance for Annexin V *in vivo* (12).

The occurrence of autoantibodies to annexin V has been described in several pathological disorders. It is concluded that extracellular annexin V provides an antigenic stimulus for autoantibody production. Such autoantibodies may have a detrimental role interfering with putative functions of annexin V. So it has been shown that concentrations of

anti-annexin V autoantibodies were significantly raised in sera from patients with rheumatoid arthritis compared to normal controls (13). Elevation in the anti-Annexin V levels were furthermore detected in patients with Systemic lupus erythematosus (SLE), in these cases higher incidences of arterial or venous thrombosis, intrauterine fetal loss and prolonged activated partial thromboplastin time were found (5,6). Anti-annexin V antibodies in sera from patients with lupus anticoagulant (LAC) were shown to exhibit anti-phospholipid and LAC properties (7,9,10,11). The presence of antibodies to Annexin V has furthermore been hypothesized to play a role in recurrent abortions, preeclampsia and fetal death (3,8).

3 Principles of the Test

Recombinant Annexin V is adsorbed onto microwells.

Human anti-Annexin V present in the sample or standard binds to the capture protein adsorbed to the microwells. A HRP-conjugated recombinant Annexin V protein is added and binds to human anti-Annexin V captured by the capture protein.

Following incubation unbound HRP-conjugated recombinant Annexin V is removed during a wash step, and substrate solution reactive with HRP is added to the wells.

A coloured product is formed in proportion to the amount of human anti-Annexin V present in the sample or standard. The reaction is terminated by addition of acid and absorbance is measured at 450 nm. A standard curve is prepared from 7 human anti-Annexin V standard dilutions and human anti-Annexin V concentration determined.

Figure 1

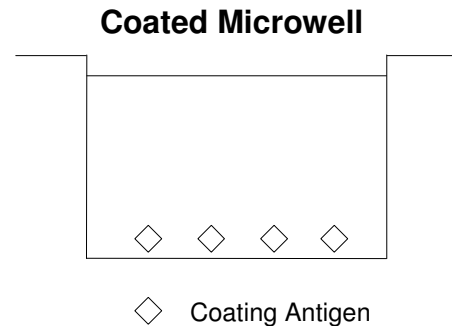

Figure 2

First Incubation

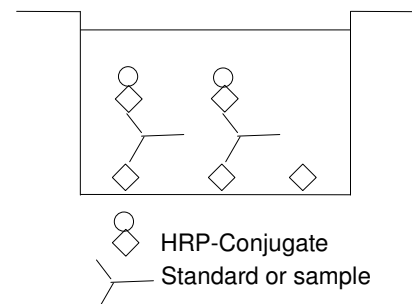

Figure 3

Second Incubation

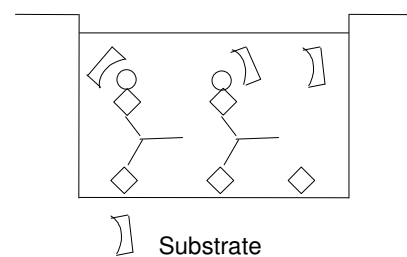
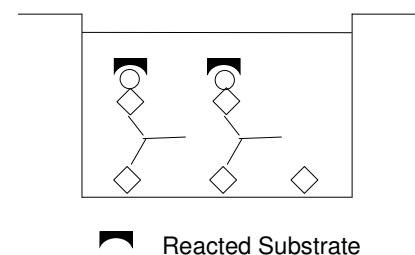

Figure 4



4 Reagents Provided

4.1 Reagents for human anti-Annexin V ELISA ALX-850-040 (96 tests)

- 1 aluminium pouch with a **Microwell Plate coated** with recombinant Annexin V
- 1 vial (6 ml) **HRP-Conjugate** recombinant Annexin V
- 2 vials human anti-Annexin V **Standard** lyophilized, 800 ng/ml upon reconstitution
- 1 vial (5 ml) **Assay Buffer Concentrate** 20x (PBS with 1% Tween 20 and 10% BSA)
- 1 bottle (50 ml) **Wash Buffer Concentrate** 20x (PBS with 1% Tween 20)
- 1 vial (15 ml) **Substrate Solution** (tetramethyl-benzidine)
- 1 vial (15 ml) **Stop Solution** (1M Phosphoric acid)
- 1 vial (0.4 ml) **Blue-Dye**
- 1 vial (0.4 ml) **Green-Dye**
- 2 **Adhesive Films**

4.2 Reagents for human anti-Annexin V ELISA (10x96 tests)

- 10 aluminium pouches with a **Microwell Plate coated** with recombinant Annexin V
- 10 vials (6 ml) **HRP-Conjugate** recombinant Annexin V
- 10 vials human anti-Annexin V **Standard** lyophilized, 800 ng/ml upon reconstitution
- 2 vials (5 ml) **Assay Buffer Concentrate** 20x (PBS with 1% Tween 20 and 10% BSA)
- 4 bottles (50 ml) **Wash Buffer Concentrate** 20x (PBS with 1% Tween 20)
- 10 vials (15 ml) **Substrate Solution** (tetramethyl-benzidine)
- 10 vials (15 ml) **Stop Solution** (1M Phosphoric acid)
- 6 vials (0.4 ml) **Blue-Dye**
- 6 vials (0.4 ml) **Green-Dye**
- 10 **Adhesive Films**

5 Storage Instructions – ELISA Kit

Store kit reagents between 2° and 8°C. Immediately after use remaining reagents should be returned to cold storage (2° to 8°C). Expiry of the kit and reagents is stated on labels.

Expiry of the kit components can only be guaranteed if the components are stored properly, and if, in case of repeated use of one component, this reagent is not contaminated by the first handling.

6 Specimen Collection and Storage Instructions

Cell culture supernatant and serum were tested with this assay. Other biological samples might be suitable for use in the assay. Remove serum from the clot as soon as possible after clotting.

Pay attention to a possible “**Hook Effect**” due to high sample concentrations (see chapter 11).

Samples containing a visible precipitate must be clarified prior to use in the assay. Do not use grossly hemolyzed or lipemic specimens.

Samples should be aliquoted and must be stored frozen at -20°C to avoid loss of bioactive human anti-Annexin V. If samples are to be run within 24 hours, they may be stored at 2° to 8°C (for sample stability refer to 13.5).

Avoid repeated freeze-thaw cycles. Prior to assay, the frozen sample should be brought to room temperature slowly and mixed gently.

7 Materials Required But Not Provided

- 5 ml and 10 ml graduated pipettes
- 5 μ l to 1000 μ l adjustable single channel micropipettes with disposable tips
- 50 μ l to 300 μ l adjustable multichannel micropipette with disposable tips
- Multichannel micropipette reservoir
- Beakers, flasks, cylinders necessary for preparation of reagents
- Device for delivery of wash solution (multichannel wash bottle or automatic wash system)
- Microwell strip reader capable of reading at 450 nm (620 nm as optional reference wave length)
- Glass-distilled or deionized water
- Statistical calculator with program to perform regression analysis

8 Precautions for Use

- All chemicals should be considered as potentially hazardous. We therefore recommend that this product is handled only by those persons who have been trained in laboratory techniques and that it is used in accordance with the principles of good laboratory practice. Wear suitable protective clothing such as laboratory overalls, safety glasses and gloves. Care should be taken to avoid contact with skin or eyes. In the case of contact with skin or eyes wash immediately with water. See material safety data sheet(s) and/or safety statement(s) for specific advice.
- Reagents are intended for research use only and are not for use in diagnostic or therapeutic procedures.
- Do not mix or substitute reagents with those from other lots or other sources.
- Do not use kit reagents beyond expiration date on label.
- Do not expose kit reagents to strong light during storage or incubation.
- Do not pipette by mouth.
- Do not eat or smoke in areas where kit reagents or samples are handled.
- Avoid contact of skin or mucous membranes with kit reagents or specimens.
- Rubber or disposable latex gloves should be worn while handling kit reagents or specimens.
- Avoid contact of substrate solution with oxidizing agents and metal.
- Avoid splashing or generation of aerosols.
- In order to avoid microbial contamination or cross-contamination of reagents or specimens which may invalidate the test use disposable pipette tips and/or pipettes.
- Use clean, dedicated reagent trays for dispensing the conjugate and substrate reagent.

- Exposure to acid inactivates the conjugate.
- Glass-distilled water or deionized water must be used for reagent preparation.
- Substrate solution must be at room temperature prior to use.
- Decontaminate and dispose specimens and all potentially contaminated materials as they could contain infectious agents. The preferred method of decontamination is autoclaving for a minimum of 1 hour at 121.5 °C.
- Liquid wastes not containing acid and neutralized waste may be mixed with sodium hypochlorite in volumes such that the final mixture contains 1.0% sodium hypochlorite. Allow 30 minutes for effective decontamination. Liquid waste containing acid must be neutralized prior to the addition of sodium hypochlorite.

9 Preparation of Reagents

Buffer Concentrates should be brought to room temperature and should be diluted before starting the test procedure.

If crystals have formed in the **Buffer Concentrates**, warm them gently until they have completely dissolved.

9.1 Wash Buffer (1x)

Pour entire contents (50 ml) of the **Wash Buffer Concentrate** (20x) into a clean 1000 ml graduated cylinder. Bring to final volume of 1000 ml with glass-distilled or deionized water. Mix gently to avoid foaming. The pH of the final solution should adjust to 7.4.

Transfer to a clean wash bottle and store at 2° to 25°C. Please note that Wash Buffer (1x) is stable for 30 days.

Wash Buffer (1x) may also be prepared as needed according to the following table:

Number of Strips	Wash Buffer Concentrate (20x) (ml)	Distilled Water (ml)
1 - 6	25	475
1 - 12	50	950

9.2 Assay Buffer (1x)

Pour the entire contents (5 ml) of the **Assay Buffer Concentrate** (20x) into a clean 100 ml graduated cylinder. Bring to final volume of 100 ml with distilled water. Mix gently to avoid foaming.

Store at 2° to 8°C. Please note that the Assay Buffer (1x) is stable for 30 days.

Assay Buffer (1x) may also be prepared as needed according to the following table:

Number of Strips	Assay Buffer Concentrate (20x) (ml)	Distilled Water (ml)
1 - 6	2.5	47.5
1 - 12	5.0	95.0

9.3 Human anti-Annexin V Standard

Reconstitute **human anti-Annexin V standard** by addition of distilled water.

Reconstitution volume is stated on the label of the standard vial. Swirl or mix gently to insure complete and homogeneous solubilization (concentration of reconstituted standard = 800 ng/ml).

Allow the reconstituted standard to sit for a minimum of 10 minutes. Mix well prior to making dilutions.

After usage remaining standard cannot be stored and has to be discarded.

Standard dilutions can be prepared directly on the microwell plate (see 10.c) or alternatively in tubes (see 9.3.1).

9.3.1 External Standard Dilution

Label 7 tubes, one for each standard point.

S1, S2, S3, S4, S5, S6, S7

Then prepare 1:2 serial dilutions for the standard curve as follows:

Pipette 225 μ l of Assay Buffer (1x) into each tube.

Pipette 225 μ l of reconstituted standard (concentration = 800 ng/ml) into the first tube, labelled S1, and mix (concentration of standard 1 = 400 ng/ml).

Pipette 225 μ l of this dilution into the second tube, labelled S2, and mix thoroughly before the next transfer.

Repeat serial dilutions 5 more times thus creating the points of the standard curve (see Figure 5).

Assay Buffer (1x) serves as blank.

Figure 5

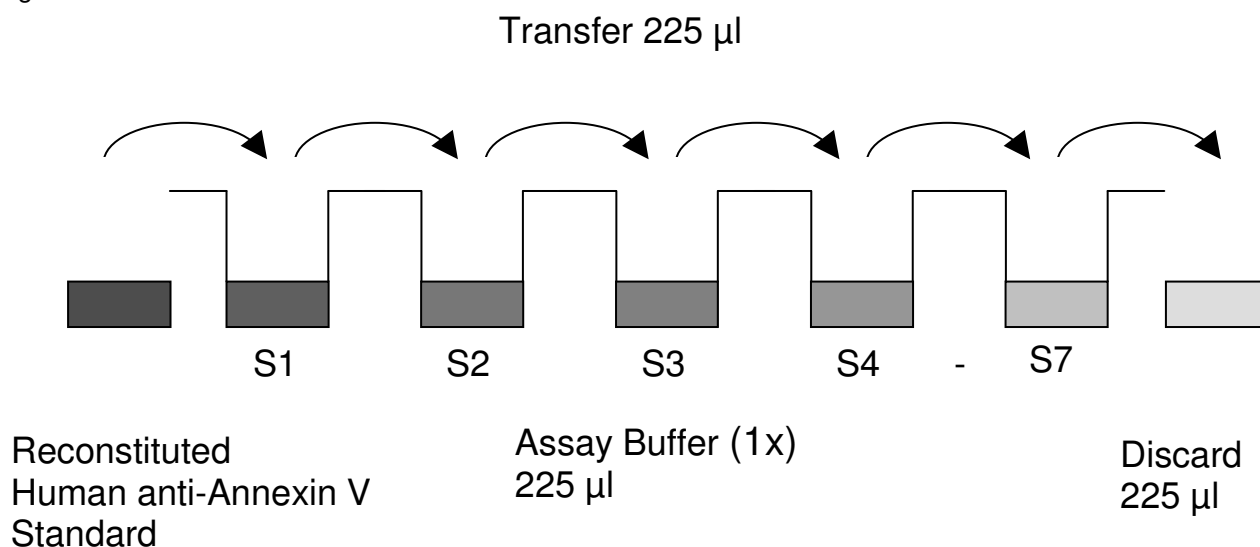

9.4 Addition of Colour-giving Reagents: Blue-Dye, Green-Dye

In order to help our customers to avoid any mistakes in pipetting the Bender MedSystems ELISAs, Bender MedSystems offers a tool that helps to monitor the addition of even very small volumes of a solution to the reaction well by giving distinctive colours to each step of the ELISA procedure.

This procedure is optional, does not in any way interfere with the test results, and is designed to help the customer with the performance of the test, but can also be omitted, just following the instruction booklet.

Alternatively, the dye solutions from the stocks provided (**Blue-Dye**, **Green-Dye**) can be added to the reagents according to the following guidelines:

1. **Diluent:** Before standard and sample dilution add the **Blue-Dye** at a dilution of 1:250 (see table below) to the appropriate diluent (1x) according to the test protocol. After addition of **Blue-Dye**, proceed according to the instruction booklet.

5 ml Assay Buffer (1x)	20 µl Blue-Dye
12 ml Assay Buffer (1x)	48 µl Blue-Dye
50 ml Assay Buffer (1x)	200 µl Blue-Dye

2. HRP-Conjugate:

Before dilution of the concentrated HRP-Conjugate add the **Green-Dye** at a dilution of 1:100 (see table below) to the Assay Buffer (1x) used for the final conjugate dilution. Proceed after addition of **Green-Dye** according to the instruction booklet: Preparation of HRP-Conjugate.

3 ml Assay Buffer (1x)	30 µl Green-Dye
6 ml Assay Buffer (1x)	60 µl Green-Dye

10 Test Protocol

- a. Determine the number of microwell strips required to test the desired number of samples plus appropriate number of wells needed for running blanks and standards. Each sample, standard, blank and optional control sample should be assayed in duplicate. Remove extra microwell strips from holder and store in foil bag with the desiccant provided at 2°-8 °C sealed tightly.
- b. Wash the microwell strips twice with approximately 400 µl **Wash Buffer** per well with thorough aspiration of microwell contents between washes. Allow the Wash Buffer to sit in the wells for about **10 – 15 seconds** before aspiration. Take care not to scratch the surface of the microwells.
After the last wash step, empty wells and tap microwell strips on absorbent pad or paper towel to remove excess Wash Buffer. Use the microwell strips immediately after washing. Alternatively microwell strips can be placed upside down on a wet absorbent paper for not longer than 15 minutes. **Do not allow wells to dry.**
- c. **Standard dilution on the microwell plate** (Alternatively the standard dilution can be prepared in tubes - see 9.3.1):
Add 100 µl of Assay Buffer (1x) in duplicate to all **standard wells**. Pipette 100 µl of prepared **standard** (see Preparation of Standard 9.3, concentration = 800 ng/ml) in duplicate into well A1 and A2 (see Table 1). Mix the contents of wells A1 and A2 by repeated aspiration and ejection (concentration of standard 1, S1 = 400 ng/ml), and transfer 100 µl to wells B1 and B2, respectively (see Figure 6). Take care not to scratch the inner surface of the microwells. Continue this procedure 5 times, creating two rows of human anti-Annexin V standard dilutions ranging from 400.0 to 6.3 ng/ml. Discard 100 µl of the contents from the last microwells (G1, G2) used.

Figure 6

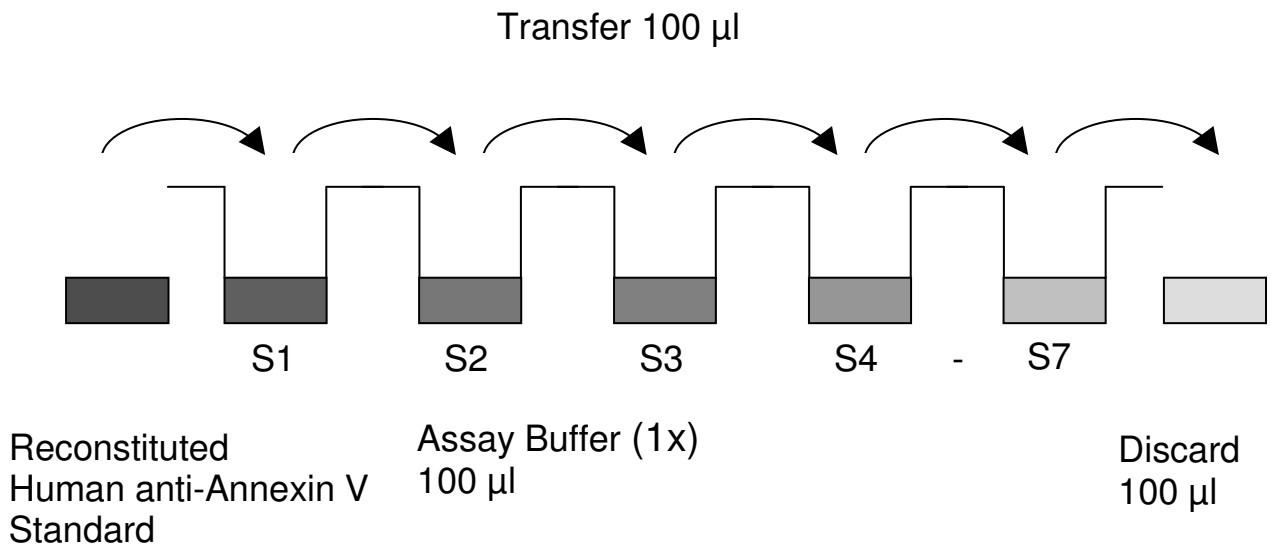

In case of an **external standard dilution** (see 9.3.1), pipette 100 μ l of these standard dilutions (S1 - S7) in the standard wells according to Table 1.

Table 1

Table depicting an example of the arrangement of blanks, standards and samples in the microwell strips:

	1	2	3	4
A	Standard 1 (400.0 ng/ml)	Standard 1 (400.0 ng/ml)	Sample 1	Sample 1
B	Standard 2 (200.0 ng/ml)	Standard 2 (200.0 ng/ml)	Sample 2	Sample 2
C	Standard 3 (100.0 ng/ml)	Standard 3 (100.0 ng/ml)	Sample 3	Sample 3
D	Standard 4 (50.0 ng/ml)	Standard 4 (50.0 ng/ml)	Sample 4	Sample 4
E	Standard 5 (25.0 ng/ml)	Standard 5 (25.0 ng/ml)	Sample 5	Sample 5
F	Standard 6 (12.5 ng/ml)	Standard 6 (12.5 ng/ml)	Sample 6	Sample 6
G	Standard 7 (6.3 ng/ml)	Standard 7 (6.3 ng/ml)	Sample 7	Sample 7
H	Blank	Blank	Sample 8	Sample 8

- d. Add 100 µl of **Assay Buffer (1x)** in duplicate to the **blank wells**.
- e. Add 50 µl of **Assay Buffer (1x)** to the **sample wells**.
- f. Add 50 µl of each **sample** in duplicate to the **sample wells**.
- g. Add 50 µl of **HRP-Conjugate** to all wells.
- h. Cover with an adhesive film and incubate at room temperature (18 to 25°C) for 2 hours, without shaking.
- i. Remove adhesive film and empty wells. **Wash** microwell strips 3 times according to point b. of the test protocol. Proceed immediately to the next step.
- j. Pipette 100 µl of **TMB Substrate Solution** to all wells.
- k. Incubate the microwell strips at room temperature (18° to 25°C) for about 10 min. Avoid direct exposure to intense light.

The colour development on the plate should be monitored and the substrate reaction stopped (see next point of this protocol) before positive wells are no longer properly recordable. Determination of the ideal time period for colour development has to be done individually for each assay.

It is recommended to add the stop solution when the highest standard has developed a dark blue colour. Alternatively the colour development can be monitored by the ELISA reader at 620 nm. The substrate reaction should be stopped as soon as Standard 1 has reached an OD of 0.6 – 0.65.

- l. Stop the enzyme reaction by quickly pipetting 100 µl of **Stop Solution** into each well. It is important that the Stop Solution is spread quickly and uniformly throughout the microwells to completely inactivate the enzyme. Results must be read immediately after the Stop Solution is added or within one hour if the microwell strips are stored at 2 - 8°C in the dark.
- m. Read absorbance of each microwell on a spectro-photometer using 450 nm as the primary wave length (optionally 620 nm as the reference wave length; 610 nm to 650 nm is acceptable). Blank the plate reader according to the manufacturer's instructions by using the

blank wells. Determine the absorbance of both the samples and the standards.

Note: In case of incubation without shaking the obtained O.D. values may be lower than indicated below. Nevertheless the results are still valid.

11 Calculation of Results

- Calculate the average absorbance values for each set of duplicate standards and samples. Duplicates should be within 20 per cent of the mean value.
- Create a standard curve by plotting the mean absorbance for each standard concentration on the ordinate against the human anti-Annexin V concentration on the abscissa. Draw a best fit curve through the points of the graph (a 5-parameter curve fit is recommended).
- To determine the concentration of circulating human anti-Annexin V for each sample, first find the mean absorbance value on the ordinate and extend a horizontal line to the standard curve. At the point of intersection, extend a vertical line to the abscissa and read the corresponding human anti-Annexin V concentration.
- **If instructions in this protocol have been followed samples have been diluted 1:2 (50 µl sample + 50 µl Assay Buffer (1x)), the concentration read from the standard curve must be multiplied by the dilution factor (x 2).**
- **Calculation of samples with a concentration exceeding standard 1 may result in incorrect, low human anti-Annexin V levels (Hook Effect). Such samples require further external predilution according to expected human anti-Annexin V values with Assay Buffer (1x) in order to precisely quantitate the actual human anti-Annexin V level.**
- It is suggested that each testing facility establishes a control sample of known human anti-Annexin V concentration and runs this additional control with each assay. If the values obtained are not within the expected range of the control, the assay results may be invalid.
- A representative standard curve is shown in Figure 7. This curve cannot be used to derive test results. Each laboratory must prepare a standard curve for each group of microwell strips assayed.

Figure 7

Representative standard curve for human anti-Annexin V ELISA. Human anti-Annexin V was diluted in serial 2-fold steps in Assay Buffer (1x). Do not use this standard curve to derive test results. A standard curve must be run for each group of microwell strips assayed.

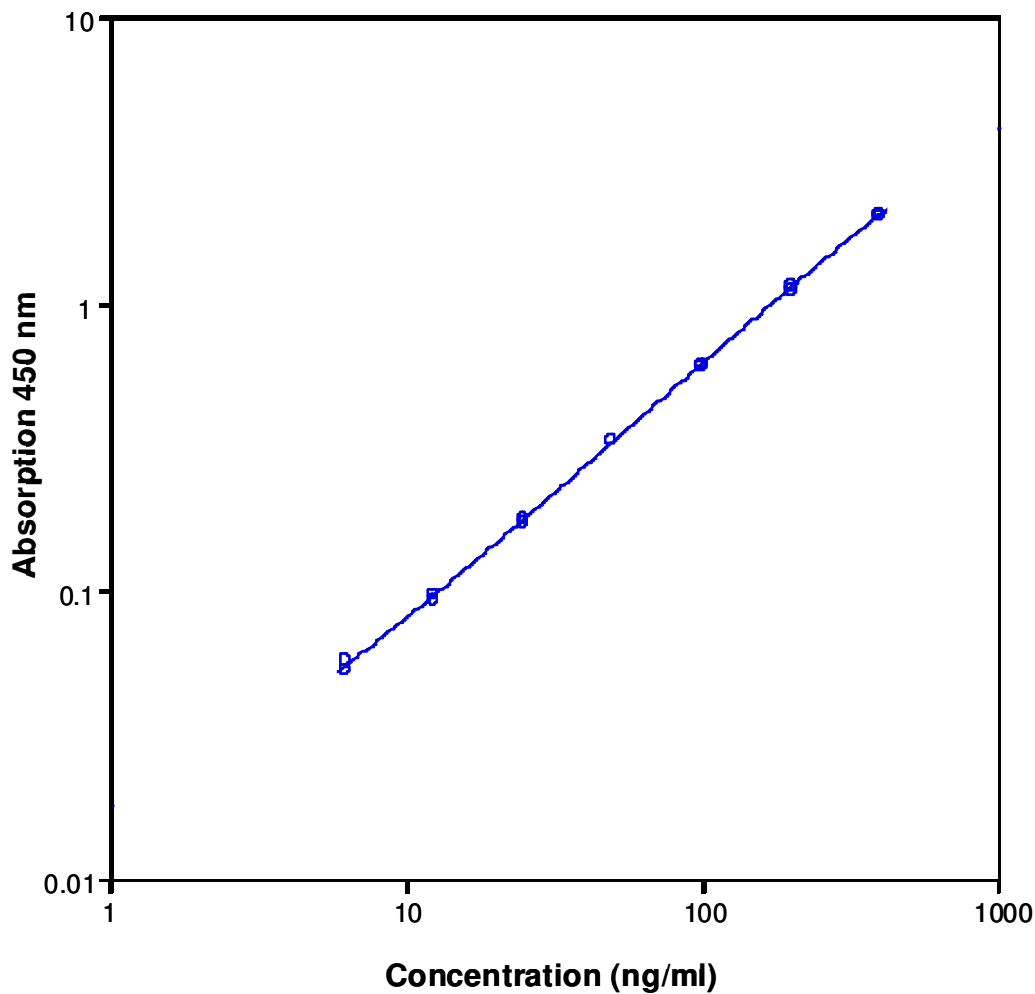

Table 2

Typical data using the human anti-Annexin V ELISA

Measuring wavelength: 450 nm

Reference wavelength: 620 nm

Standard	Human anti-Annexin V Concentration (ng/ml)	O.D. at 450 nm	Mean O.D. at 450 nm	C.V. (%)
1	400.0	2.022	2.042	1.4
	400.0	2.061		
2	200.0	1.121	1.138	2.1
	200.0	1.155		
3	100.0	0.603	0.610	1.5
	100.0	0.616		
4	50.0	0.336	0.335	0.4
	50.0	0.334		
5	25.0	0.180	0.176	3.2
	25.0	0.172		
6	12.5	0.098	0.096	3.7
	12.5	0.093		
7	6.3	0.057	0.055	5.1
	6.3	0.053		
Blank	0	0.010	0.009	
	0	0.008		

The OD values of the standard curve may vary according to the conditions of assay performance (e.g. operator, pipetting technique, washing technique or temperature effects). Furthermore shelf life of the kit may affect enzymatic activity and thus colour intensity. Values measured are still valid.

12 Limitations

- Since exact conditions may vary from assay to assay, a standard curve must be established for every run.
- Bacterial or fungal contamination of either screen samples or reagents or cross-contamination between reagents may cause erroneous results.
- Disposable pipette tips, flasks or glassware are preferred, reusable glassware must be washed and thoroughly rinsed of all detergents before use.
- Improper or insufficient washing at any stage of the procedure will result in either false positive or false negative results. Empty wells completely before dispensing fresh wash solution, fill with Wash Buffer as indicated for each wash cycle and do not allow wells to sit uncovered or dry for extended periods.

13 Performance Characteristics

13.1 Sensitivity

The limit of detection of human anti-Annexin V defined as the analyte concentration resulting in an absorbance significantly higher than that of the dilution medium (mean plus 2 standard deviations) was determined to be 1.2 ng/ml (mean of 6 independent assays).

13.2 Reproducibility

13.2.1 Intra-assay

Reproducibility within the assay was evaluated in 3 independent experiments. Each assay was carried out with 6 replicates of 8 samples (natural and spiked serum samples as well as cell culture samples) containing different concentrations of human anti-Annexin V. 2 standard curves were run on each plate. Data below show the mean human anti-Annexin V concentration and the coefficient of variation for each sample (see Table 3). The calculated overall intra-assay coefficient of variation was 2.0%.

Table 3

The mean human anti-Annexin V concentration and the coefficient of variation for each sample

Sample	Experiment	Mean Human anti-Annexin V Concentration (ng/ml)	Coefficient of Variation (%)
1	1	311.6	4.6
	2	314.6	2.6
	3	318.2	1.5
2	1	320.8	0.3
	2	331.1	1.1
	3	335.3	4.9
3	1	171.6	0.6
	2	169.5	1.3
	3	165.8	1.8
4	1	148.1	2.4
	2	154.3	1.2
	3	153.1	1.1
5	1	162.5	3.0
	2	150.9	0.5
	3	146.0	0.9
6	1	60.2	3.4
	2	53.4	1.0
	3	49.2	1.6
7	1	27.5	2.2
	2	29.0	3.6
	3	26.7	1.2
8	1	40.3	0.6
	2	42.0	1.6
	3	39.6	5.0

13.2.2 Inter-assay

Assay to assay reproducibility within one laboratory was evaluated in 3 independent experiments. Each assay was carried out with 6 replicates of 8 samples (natural and spiked serum samples as well as cell culture samples) containing different concentrations of human anti-Annexin V. 2 standard curves were run on each plate. Data below show the mean human anti-Annexin V concentration and the coefficient of variation calculated on 18 determinations of each sample (see Table 4). The calculated overall inter-assay coefficient of variation was 3.8%.

Table 4

The mean human anti-Annexin V concentration and the coefficient of variation of each sample

Sample	Mean Human anti-Annexin V Concentration (ng/ml)	Coefficient of Variation (%)
1	314.8	1.1
2	329.1	2.3
3	168.9	1.7
4	151.8	2.1
5	153.2	5.5
6	54.3	10.2
7	27.7	4.2
8	40.7	3.0

13.3 Spike Recovery

The spike recovery was evaluated by spiking 4 levels of purified human anti-Annexin V into serum and cell culture supernatant samples. Recoveries were determined in 3 independent experiments with 6 replicates each.

The amount of endogenous human anti-Annexin V in unspiked serum and cell culture supernatant was subtracted from the spike values. The recovery ranged from 74% to 100% with an overall mean recovery of 86%.

13.4 Dilution Parallelism

4 spiked serum and cell culture supernatant samples with different levels of human anti-Annexin V were analysed at serial 2 fold dilutions with 4 replicates each.

The recovery ranged from 96% to 120% with an overall recovery of 107% (see Table 5).

Table 5

Sample	Dilution	Expected Human anti-Annexin V Concentration (ng/ml)	Observed Human anti-Annexin V Concentration (ng/ml)	Recovery of Expected Human anti-Annexin V Concentration (%)
1	1:2	--	325.0	--
	1:4	162.5	188.2	115
	1:8	81.3	98.2	120
2	1:2	--	321.7	--
	1:4	160.9	162.2	101
	1:8	80.4	85.6	106
3	1:2	--	178.0	--
	1:4	89.0	96.5	109
	1:8	44.5	48.8	110
4	1:2	--	168.4	--
	1:4	84.2	80.7	96
	1:8	42.1	42.3	101

13.5 Sample Stability

13.5.1 Freeze-Thaw Stability

Aliquots of spiked serum samples were stored at -20 °C and thawed 5 times, and the human anti-Annexin V levels determined. There was no significant loss of human anti-Annexin V immunoreactivity detected by freezing and thawing.

13.5.2 Storage Stability

Aliquots of spiked serum samples were stored at -20 °C, 2-8 °C, room temperature (RT) and at 37 °C, and the human anti-Annexin V level determined after 24 h. There was no significant loss of human anti-Annexin V immunoreactivity detected during storage at -20 °C, 2-8 °C and RT.

A significant loss of human anti-Annexin V immunoreactivity (50%) was detected during storage at 37 °C after 24 h.

13.6 Specificity

The interference of circulating factors of the immune system was evaluated by spiking these proteins at physiologically relevant concentrations into a human anti-Annexin V positive serum. There was no crossreactivity detected.

13.7 Expected Values

A panel of serum samples from randomly selected apparently healthy donors (males and females) was tested for human anti-Annexin V. There were no detectable human anti-Annexin V levels found.

14 Bibliography

- 1) Benz J., Hofmann A. Annexins: from structure to function. *Biol. Chem.* 1997 Mar;378(3-4):177-183.
- 2) Dubois T, Oudinet J.P., Mira J.P., Russo-Marie F. Annexins and protein kinases C. *Biochim. Biophys Acta* 1996 Oct. 11;1313(3):290-294.
- 3) Galli M. Non beta 2-glycoprotein I cofactors for antiphospholipid antibodies. *Lupus* 1996 Oct.;5(5):388-392.
- 4) Huber R., Berendes R., Burger A., Luecke H., Karshikov A. Annexin V-crystal structure and its implications on function. *Behring Inst. Mitt.* 1992 Apr; 91:107-125.
- 5) Kaburaki J., Ikeda Y. Thrombosis in patients with SLE and antiphospholipid syndrome. *Rinsho Ketsueki* 1995 Apr.;36(4):320-324.
- 6) Kaburaki J., Kuwana M., Yamamoto M., Kawai S., Ikeda Y. Clinical significance of anti-annexin V antibodies in patients with systemic lupus erythematosus. *Am. J. Hematol.* 1997 Mar.;54(3):209-213.
- 7) Kuragaki C., Kidoguchi K., Nakamura N., Wada Y. Anti-annexin V antibodies in plasma and serum samples from patients with lupus anticoagulant. *Am. J. Hematol.* 1995 Sep.;50(1):68
- 8) Matsuda J., Gotoh M., Saitoh N., Gohchi K., Tsukamoto M., Yamamoto T. Anti-annexin antibody in the sera of patients with habitual fetal loss or preeclampsia. *Thromb. Res.* 1994 Jul. 1; 75(1):105-106.x
- 9) Matsuda J., Saitoh N., Gohchi K., Gotoh M., Tsukamoto M. Anti-annexin V antibody in systemic lupus erythematosus patients with lupus anticoagulant and/or anticardiolipin antibody. *Am. J. Hematol.* 1994 Sep.; 47(1):56-58.
- 10) Nakamura N., Kuragaki C., Shidara Y., Yamaji K., Wada Y. Antibody to annexin V has anti-phospholipid and lupus anticoagulant properties. *Am. J. Hematol.* 1995 Aug.;49(4):347-348.

- 11) Nakamura N., Shidara Y., Kawaguchi N., Azuma C., Mitsuda N., Onishi S., Yamaji K., Wada Y. Lupus anticoagulant autoantibody induces apoptosis in umbilical vein endothelial cells: involvement of annexin V. *Biochem. Biophys. Res. Commun.* 1994 Dec. 15;205(2):1488-1493.
- 12) Reutelingsperger C.P., van Heerde W.L. Annexin V, the regulator of phosphatidylserine-catalyzed inflammation and coagulation during apoptosis. *Cell Mol. Life Sci.* 1997 Jun; 53(6):527-532.
- 13) Rodriguez-Garcia M.I., Fernandez J.A., Rodriguez A., Fernandez M.P., Gutierrez C., Torre-Alonso J.C. Annexin V autoantibodies in rheumatoid arthritis. *Ann. Rheum. Dis.* 1996 Dec.; 55(12):895-900.
- 14) Von der Mark K., Mollenhauer J. Annexin V interactions with collagen. *Cell Mol. Life Sci.* 1997 Jun; 53 (6):539-545.

15. Ordering Information

For orders please contact:

NORTH/SOUTH AMERICA

ENZO LIFE SCIENCES
INTERNATIONAL, INC.
5120 Butler Pike
Plymouth Meeting, PA 19462-1202
USA
Phone: 1-800-942-0430/(610) 941-0430
Fax: (610) 941-9252
E-mail: info-usa@enzolifesciences.com

GERMANY

ENZO LIFE SCIENCES GMBH
Marie-Curie-Strasse 8
DE-79539 Lörrach
Germany
Phone: +49/0 7621 5500 526
Fax: +49/0 7621 5500 527
E-mail: info-de@enzolifesciences.com

SWITZERLAND & REST OF EUROPE

ENZO LIFE SCIENCES AG
Industriestrasse 17, Postfach
CH-4415 Lausen
Switzerland
Phone: +41/0 61 926 89 89
Fax: +41/0 61 926 89 79
E-mail: info-ch@enzolifesciences.com

BENELUX

ENZO LIFE SCIENCES BVBA
Melkerijweg 3
BE-2240 Zandhoven
Belgium
Phone: +32/0 3 466 04 20
Fax: +32/0 3 466 04 29
E-mail: info-be@enzolifesciences.com

UK & IRELAND

ENZO LIFE SCIENCES (UK) LTD.
Palatine House
Matford Court
Exeter EX2 8NL
UK
Phone: 0845 601 1488 (UK customers)
+44/0 1392 825900 (from overseas)
Fax: +44/0 1392 825910
E-mail: info-uk@enzolifesciences.com

www.enzolifesciences.com

Cat. No: ALX-850-040

16 Reagent Preparation Summary

16.1 Wash Buffer (1x)

Add **Wash Buffer Concentrate** 20x (50 ml) to 950 ml distilled water.

Number of Strips	Wash Buffer Concentrate (ml)	Distilled Water (ml)
1 - 6	25	475
1 - 12	50	950

16.2 Assay Buffer (1x)

Add **Assay Buffer Concentrate** 20x (5 ml) to 95 ml distilled water.

Number of Strips	Assay Buffer Concentrate (ml)	Distilled Water (ml)
1 - 6	2.5	47.5
1 - 12	5.0	95.0

16.3 Human anti-Annexin V Standard

Reconstitute lyophilized **human anti-Annexin V standard** with distilled water. (Reconstitution volume is stated on the label of the standard vial.)

17 Test Protocol Summary

1. Determine the number of microwell strips required.
2. Wash microwell strips twice with Wash Buffer.
3. Standard dilution on the microwell plate: Add 100 µl Assay Buffer (1x), in duplicate, to all standard wells. Pipette 100 µl prepared standard into the first wells and create standard dilutions by transferring 100 µl from well to well. Discard 100 µl from the last wells.
Alternatively external standard dilution in tubes (see 9.3.1): Pipette 100 µl of these standard dilutions in the microwell strips.
4. Add 100 µl Assay Buffer (1x), in duplicate, to the blank wells.
5. Add 50 µl Assay Buffer (1x) to sample wells.
6. Add 50 µl sample in duplicate, to designated sample wells.
7. Add 50 µl HRP-Conjugate to all wells.
8. Cover microwell strips and incubate 2 hours at room temperature (18° to 25°C) without shaking.
9. Empty and wash microwell strips 3 times with Wash Buffer.
10. Add 100 µl of TMB Substrate Solution to all wells.
11. Incubate the microwell strips for about 10 minutes at room temperature (18° to 25°C).
12. Add 100 µl Stop Solution to all wells.
13. Blank microwell reader and measure colour intensity at 450 nm.

Note: If instructions in this protocol have been followed samples have been diluted 1:2 (50 µl sample + 50 µl Assay Buffer (1x)), the concentration read from the standard curve must be multiplied by the dilution factor (x 2).